

## SAFETY & INSTRUCTIONS FOR LS SERIES

**PLEASE READ CAREFULLY BEFORE INSTALLING OR OPERATING THIS POWER SUPPLY**

### Power Supply Warning Symbols

Caution,  
Risk of electric shock



Caution  
Refer to accompanying documentation



Order Code:

Series Code	kV	Polarity	Options Code	Temp Co	PPM/ °C
LS 001=	1kV	P= +ve	IP = Precision I mon		10
2.5 =	2.5kV	N= -ve	PP= + Internal Reference		
005=	5kV		FP= + Internal Pot & Reference		

e.g. LS010NIP010 = 10kV negative LS without Pot & Ref options

For Internal or External Potentiometer operation the PP or FP option codes **must** be specified.

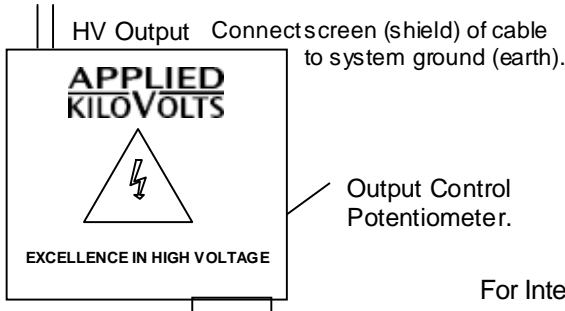

For Internal Potentiometer operation (FP), Links are factory fitted internally.

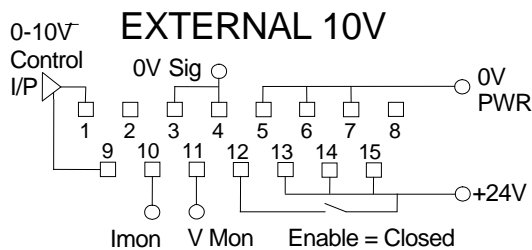

### EXTERNAL POTENTIOMETER

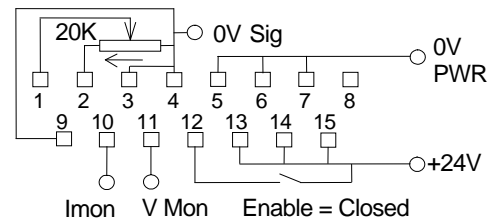

15W D type Plug

- Pin 1 Analogue input voltage 0 to 10V gives 0 to max O/P
- Pin 2 Internal 10V reference – if fitted
- Pin 3 Signal 0V for monitor signals (connected internally to Pins 4, 5, 6 & 7)
- Pin 4 Signal 0V for monitor signals (connected internally to Pin 3, 5, 6 & 7)
- Pin 5 Power 0V (Internally connected to Pins 3, 4, 6 & 7)
- Pin 6 Power 0V (Internally connected to Pins 3, 4, 5 & 7)
- Pin 7 Power 0V (Internally connected to Pins 3, 4, 5 & 6)

- Pin 8 not connected
- Pin 9 Analogue voltage input return
- Pin 10 Precision Imon (0-10V = 0 to max I ) Zout 10k
- Pin 11 Vmon Signal (0-10V = 0 to max V) Zout 10k
- Pin 12 Enable High = +24V = Enable O/C or 0V = Inhibit (Do not use as safety interlock)
- Pin 13 24V supply (connected internally to 14 & 15)
- Pin 14 24V supply (connected internally to 13 & 15)
- Pin 15 24V supply (connected internally to 13 & 14)

Notes: Control Voltage (Pin 1) must be between -0.5V & 10.2V  
Enable i/p has a 100k Internal pull-down to 0V Pwr

### Specification

UNIT	OUTPUT	RIPPLE	SIZE (mm)
LS001P & N	10V to 1kV @ 1mA	<1mV p/p	156 x 127 x 64
LS2.5P & N	10V to 2.5kV @ 400µA	<3mV p/p	156 x 127 x 64
LS005P & N	10V to 5kV @ 200µA	<5mV p/p	156 x 127 x 64
LS010P & N	20V to 10kV @ 100µA	<10mV p/p	156 x 127 x 64
LS015P & N	30V to 15kV @ 66.7µA	<15mV p/p	207 x 148 x 74
LS020P & N	100V to 20kV @ 50µA	<20mV p/p	207 x 148 x 74
LS030P & N	200V to 30kV @ 33.3µA	<30mV p/p	207 x 148 x 74
LS050P & N	500V to 50kV @ 20µA	<50mV p/p	333 x 204 x 114

If the equipment is used in a manner not specified, the protection provided by the equipment may be impaired.

**Input Supply Voltage** 24Vdc ± 10% at 0.15A. [ <250mA for LS050]

**Mounting** M4 Blind fasteners to front and rear of base. Max screw depth 4mm. Mechanical vibration will couple through to the output of every high voltage supply.

**Cleaning** Use a lint free cloth soaked with isopropyl alcohol, ensuring the unit is completely dry before use.

### Environmental Conditions

Indoor use only, Altitude up to 2000m, Maximum relative humidity 80% for temperatures up to 31°C, decreasing linearly to 50% relative humidity at 40°C, The unit is to be supplied from a current limited supply providing 24Vdc, impulse limited to (overvoltage) Category I of IEC60364-4-443.

Operating Temperature 0°C to +50°C,  
Storage Temperature -35°C to +85°C.

For use in an environment of pollution degree 2.

**Grounding** The case, 0V power, and o/p braid are all bonded within the unit. Please refer to details on Page 3.

**Applied Kilovolts Ltd., Woods Way, Goring by Sea, West Sussex BN12 4QY, UK.**

**Tel: +44 (0) 1903 708850 Fax +44 (0) 1903 708851**

**Web Site: AppliedKilovolts.com Email: Sales@AppliedKilovolts.com**

**General**

On receipt the unit should be carefully unpacked and inspected to ensure that no transit damage has occurred. Provided that this inspection is satisfactory and reveals no evidence of damage then installation can proceed.

If an electrical test is to be carried out prior to fitting the power supply, it is essential that the person undertaking this work has received appropriate technical training to be aware of the hazards to which that person may be exposed in performing the tests, and of measures to minimise the risks to themselves, and other personnel. Metallic or conductive tools should not be used to adjust any of the potentiometers. The unit has no user serviceable parts and should not be dismantled.

**DO NOT HANDLE OR TOUCH THESE UNITS WHEN THE SUPPLY IS CONNECTED. AFTER DISCONNECTION FROM THE SUPPLY, ALLOW 30 SECONDS BEFORE HANDLING SO THAT ALL THE CAPACITORS CAN DISCHARGE.** To ensure that the output is fully discharged, short to ground before touching any high voltage circuit.

Care should be taken not to operate the unit outside the specified limits given above; failure to do so may damage the unit, and will invalidate the warranty.

**COMPLIANCE WITH SAFETY STANDARDS**

The unit is designed to meet Normalised European Safety Standards for installation in equipment conforming to EN61010 and hence installation of the power supply unit into the equipment should comply with the following requirements.

- a. A PROTECTIVE EARTH must be provided for safety in accordance with EN61010 Part 1 : latest : Clause 6.5.1. The case of the units must be bonded to this protective earth.
- b. The output is classed as hazardous and must therefore not be accessible to operators. The output must be isolated from accessible circuits by Double Insulation or a protective screen as defined in EN61010-1.
- c. It is intended to be installed in an electrical enclosure and the unit and its input connector should not be accessible to the operator. Access should be restricted to authorised service personnel only, with use of a tool.
- d. The unit is not fitted with a fuse and so should be operated from a limited supply of <1 amp.

**INSTALLATION**

The outputs of these units are considered hazardous and should be installed such that they cannot become accessible. The output should be connected such that the shortest creepage and clearance path is to a protective earth connection. ENSURE that a LOW IMPEDANCE connection is made to the unit chassis from the system PROTECTIVE EARTH. The safety earth (ground) conductor must not contain any switches or fuses.

Under worst case conditions the unit draws a current of 0.15A [<0.25A for LS050] and any input supply cable must be of a suitable type and rating. Fuses must be fitted externally to the unit to protect unit and interconnecting wiring etc. but these should be rated to prevent nuisance failures. Care should be taken in the design of the interconnecting wiring within the system to ensure that connectors with hazardous voltages cannot be connected to accessible circuits.

Ensure that the output is connected to the load prior to operation of the unit and that a good low impedance high voltage joint is made. Sharp points on either the high voltage or return joint should be avoided as this will cause corona which will make the output appear noisy. In general a tracking distance (creepage distance) of 25mm (1 inch), per 10kV to earth is advised as a minimum to ensure no breakdown or corona occurs, a much greater distance will be required under adverse conditions. Care must be taken not to damage the cable inner when forming the connections.

During arcing, very large currents may flow, discharging the load and cable capacitance, however the unit itself will contribute <5mA. It is important that these currents return to the high voltage power supply by the shortest possible route using the screen (shield) of the output cable. Failure to observe this will result in the control terminals of the unit seeing large voltage spikes during arcing and radiation of electromagnetic interference.

Adequate ventilation should be provided to keep the unit cool. The ambient air temperature around the unit must not exceed 50°C. The unit will operate in any orientation.

**OPERATING NOTES**

- 1/ HIGH VOLTAGES ARE DANGEROUS. ENSURE THE OUTPUT IS FULLY DISCHARGED BY SHORTING TO GROUND BEFORE TOUCHING ANY HIGH VOLTAGE CIRCUIT.
- 2/ The unit is short circuit proof but care should be taken that the high voltage cannot be shorted into one of the control pin connections.
- 3/ POWER SUPPLIES WITH THE 'INTERNAL POT & REF' OPTION CODE (FP) ARE DISPATCHED WITH THE INTERNAL POT SET TO MAXIMUM. TURN DOWN TO ZERO BEFORE CONNECTING TO 24 VOLT SUPPLY.

## Installation

**The exceptionally low output noise capability of these supplies can only be achieved if great care and attention is paid to the details of the installation:**

### Screening

It is essential that **all** connections are made by well screened leads, including the power supply input connections.

### Earthing

Every different installation places different constraints on the earthing, so some experimentation may well be called for, if the rated performance is to be achieved.

Screened leads are usually best only grounded at one end, thereby avoiding ground loops. It is suggested that initially the screens are grounded at the PSU end, to the PSU's ground.

The 24V supply's 0V connection is taken to the unit's chassis, together with the braid of the HV output cable, which provides the reference for the feedback monitoring chain. So care needs to be taken to avoid earth loops with additional ground connections.

### Output Connections

It is also essential that the output be connected by a continuously screened length of output cable.

Any connectors need to be rated very conservatively for the expected voltage, or micro-discharges will occur, which can be of greater magnitude than the output noise of the PSU.

### Control Input

It is essential that the control input is generated from a highly stable reference, if the exceptional temperature stability of these units is to be realised. The unit can never be more stable than the control input to it. It is intended that the +ve control input be taken to the DAC's output, and the -ve control input be taken to the DAC's Ground Reference, thereby eliminating voltage drops through the earth connections from adding offset voltages or noise into the output.

The -ve control input is connected to 0V by a 47ohm resistor and a pair of back to back diodes, and is not intended to be more than 0.5V away from 0V.

It is also essential to filter the control input from high frequency transients coupling into it from high speed computer buses.

### Signal Returns pins 3 & 4

While these are intended as the Voltage and Current Monitor return connections, they are connected internally to the 24V supply's return on Pins 5, 6, & 7.

### Vibration

The LS family is highly optimised to reduce the effect of vibration.

However to achieve the rated output noise levels, it is essential that these units are mounted free from vibration.